



 **THE GOAT™**
Anywhere, Anytime, Anyplace



www.goverland.net



**GOVERLAND®**



Connecting daily life with rest in nature.





Designed and Built by an Architect and a Structural Engineer with a combined two decades of outdoor experience. Manufactured with high-quality, durable, and lightweight materials. Incorporates EZ Modular Expansion for room and shower addition. Introducing the unique “Z High-Top” Open/Closure Mechanism providing for greater vertical space and convenience while standing, sitting, or lounging in comfort. Lightweight Slim Side-Wall Design minimizes vehicle impact while driving whether open or off-road.





GOAT ex) Ford F150

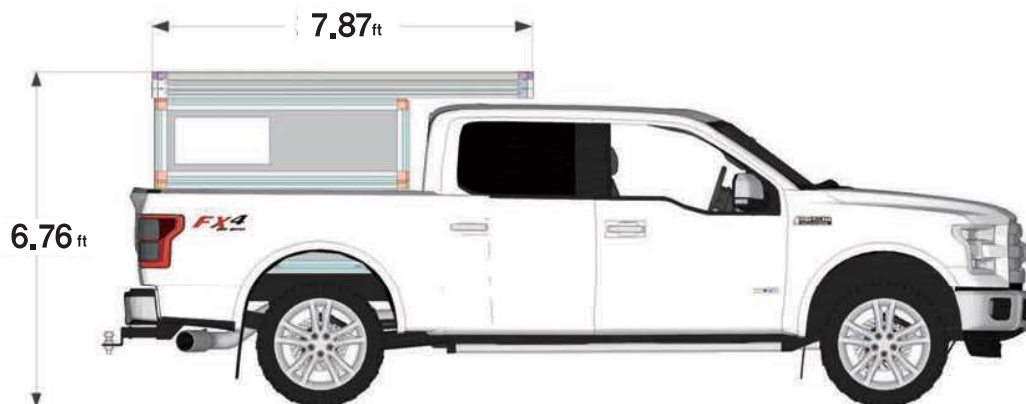
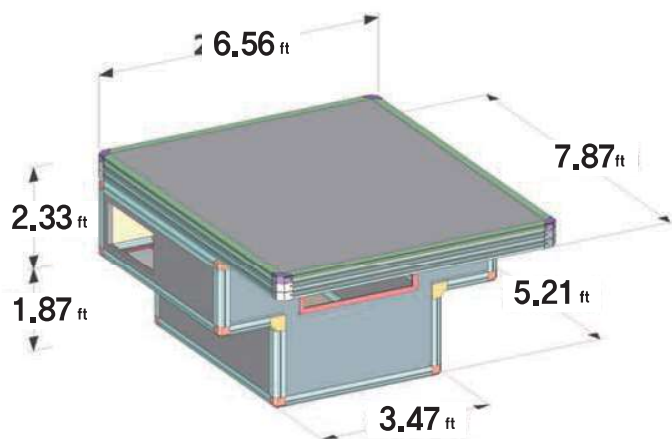



Displayed sample vehicle: Ford F150

Available in all truck sizes.

Reinforced Aluminum, SUS 304 Stainless Steel, 35mm GRP, PVDF Coating

Default Components

Camper box, Rear extension wall, Rear cover, Fly wall, Bed mat, Chair mat, Bottom storage furniture, Dimming LED lights, Floor coil mat, Water Tanks(11gal), Fastening buclod(sus 304), Rooftop tent Lock keys, Faucet kit, Gas prop stopper, Basic tool kit,

Standing Entrance

Space Scalability

Detachable

Insulation Performance

Functional Extension

Multipurpose Exterior Rails

UV Protection Fabric (99.99%)

Dimension

Width 3.47 ft / 6.56 ft

Length 5.21 ft / 7.87 ft

Expanded Bed Size

6.20 ft (L) x 6.20 ft (W) x 3.60 ft (H)

Weight

about 895 lb

GOAT (Product Configuration)

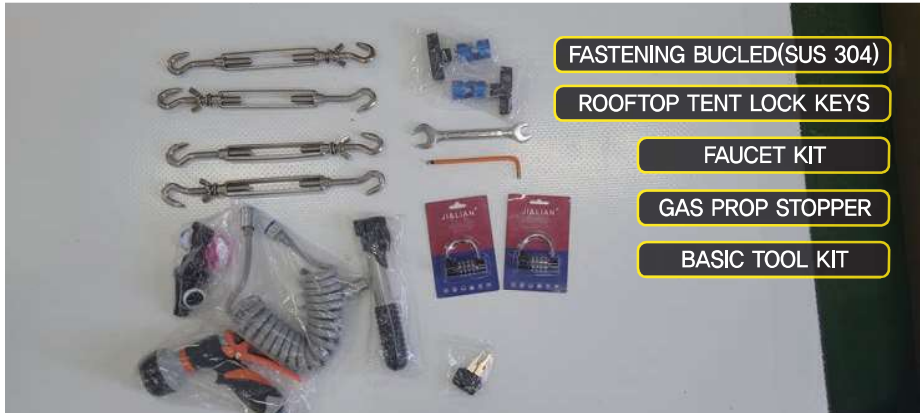

GOAT (Additional Options)

AIRNET Mattress



Swing Awning 180



Swing Awning 180 Wall Set



Air Conditioner Box

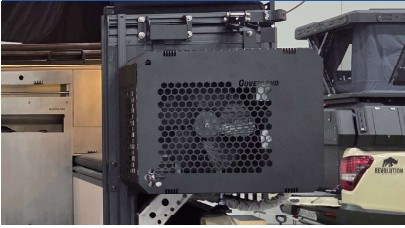

Heater Box



TV Bracket



Side Clasp Rail (Outside)



Interior Clasp Rail (Inside)



Storage Shelf Box



Lift Jack Kit



Power Supply Box (AC+DC)



Extension Cords (AC+DC)



 **GOVERLAND**[®]

MADE IN KOREA

**Manufactured in Korea with
verified components.**

※ We continuously develop a variety of accessory products using a special coupling method designed for easy mounting and detachment, both internally and externally.

Freedom
to go anywhere at any time with **GOVERLAND®**





Types of Model







Sliding Bed

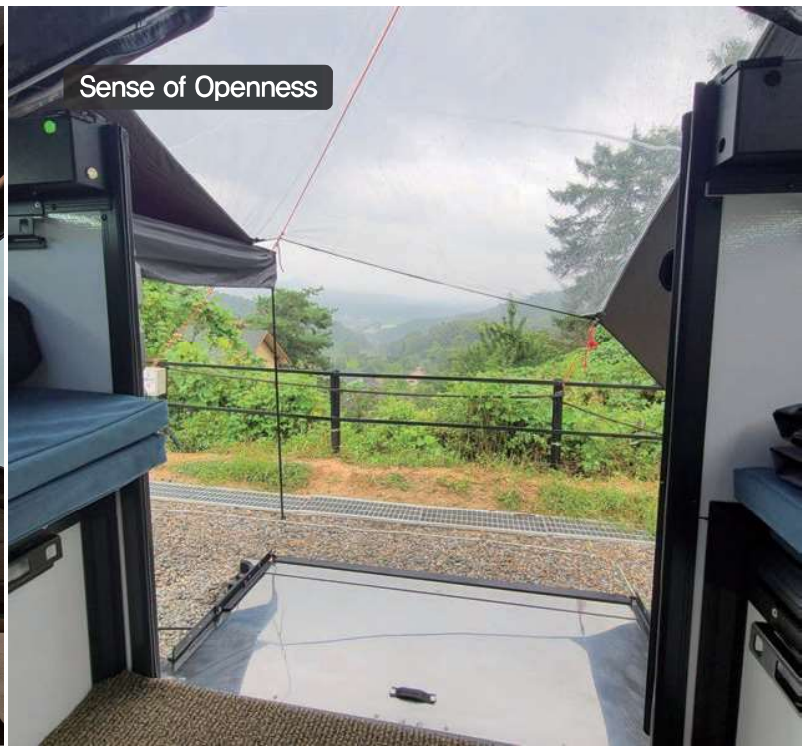

Sense of Openness



Sense of Openness



Internal Space



Mounting Storage Shelf Box



Accessory Bracket

GOVERLAND[®] Produced with Proven Parts

We meticulously manage key components through thorough performance inspections of raw materials, and we directly handle all assembly processes to ensure the highest product quality.

Main Frame (Aluminum)



BEYOND ASIAN HUB, TOWARD GLOBAL WORLD

TEST REPORT

98, Gyojukwon-ro, Gwacheon-si, Gyeonggi-do, 13810, Korea TEL 82-31-499-5390 FAX 82-31-499-6867

Report No : TAK-2023-177360 Receipt Date : 2023.12.21.
 Representative : Hong, Sung-Chul Test Completion Date : 2024.01.11.
 Company name : MARECAMP CO., Ltd.
 Address : 182, Sinnam-ro, Namyang-eup, Hwaseong-si, Gyeonggi-do, Republic of Korea.

Sample name : Goverland AL Frame

Test Results				
TEST ITEM	UNIT	SAMPLE	RESULT	TEST METHOD
Tensile Strength	N/mm ²	-	250	KS B 0802:2003
Yield Strength(0.2% offset)	N/mm ²	-	220	KS B 0802:2003
Elongation	%	-	11	KS B 0802:2003
Fe	%	-	0.17	ASTM E1251-17a
Cu	%	-	0.05	ASTM E1251-17a
Mn	%	-	0.03	ASTM E1251-17a
Mg	%	-	0.55	ASTM E1251-17a
Zr	%	-	0.02	ASTM E1251-17a
Ci	%	-	0.03	ASTM E1251-17a
Ti	%	-	0.02	ASTM E1251-17a
Sr	%	-	0.43	ASTM E1251-17a

- Test Method [KS B 0802] (Test Specimen No.5)
 - Usage of Report : QUALITY CONTROL

An Chi-young
Prepared by An Chi-young
Tel : 02-2992-3634

Oh Donghwan
Reviewed by Oh Donghwan
Tel : 1577-0891(APS 01-48)

2024.01.11

Korea Testing & Research Institute
President



QR Code for forgery

Korea Testing & Research Institute
President



QR Code for forgery

Stainless Steel Reinforcement (304)



BEYOND ASIAN HUB, TOWARD GLOBAL WORLD

TEST REPORT

98, Gyojukwon-ro, Gwacheon-si, Gyeonggi-do, 13810, Korea TEL 82-31-499-5390 FAX 82-31-499-6867

Report No : TAK-2023-177362 Receipt Date : 2023.12.21.
 Representative : Hong, Sung-Chul Test Completion Date : 2024.01.11.
 Company name : MARECAMP CO., Ltd.
 Address : 182, Sinnam-ro, Namyang-eup, Hwaseong-si, Gyeonggi-do, Republic of Korea.

Sample name : Goverland reinforced material (SUS304)

Test Results				
TEST ITEM	UNIT	SAMPLE	RESULT	TEST METHOD
C	%	-	0.05	KS D 1652 : 2022
Si	%	-	0.63	KS D 1652 : 2022
Mn	%	-	1.04	KS D 1652 : 2022
P	%	-	0.034	KS D 1652 : 2022
S	%	-	0.004	KS D 1652 : 2022
Ni	%	-	8.06	KS D 1652 : 2022
Cr	%	-	18.05	KS D 1652 : 2022

- Usage of Report : QUALITY CONTROL

Note : 1. The test results of this test report are only limited in to the samples and sample names provided by the client and do not guarantee the quality of all products of the client. You can check website (www.ktr.or.kr) or QR code to verify the authenticity of the certificate.
 2. This test report shall be used only within the purpose of its defined usage and shall not be used for public relation, advertisement and lawsuit.
 3. This test report is only valid when printed on KTR original report paper with hologram and when re-issued by KTR. The copy and the electronic file of the test report are only for reference.

Kim Hyun Jeong
Prepared by Kim Hyun Jeong
Tel : 02-2992-3662

Ki Hyunja
Reviewed by Ki Hyunja
Tel : 1577-0891(APS 01-48)

2024.01.11

Korea Testing & Research Institute
President



QR Code for forgery

Korea Testing & Research Institute
President



QR Code for forgery

PVDF Coating



BEYOND ASIAN HUB, TOWARD GLOBAL WORLD

TEST REPORT

98, Gyojukwon-ro, Gwacheon-si, Gyeonggi-do, 13810, Korea TEL 82-31-499-5390 FAX 82-31-499-6867

Report No : TAK-2023-177361 Receipt Date : 2023.12.21.
 Representative : Hong, Sung-Chul Test Completion Date : 2024.01.11.
 Company name : MARECAMP CO., Ltd.
 Address : 182, Sinnam-ro, Namyang-eup, Hwaseong-si, Gyeonggi-do, Republic of Korea.

Sample name : Goverland Paint Coating

Test Results				
TEST ITEM	UNIT	SAMPLE	RESULT	TEST METHOD
Dry-Film Thickness	um	-	45	AAMA 2605-13
Specular Gloss(60°)	GU	-	52	AAMA 2605-13
Pencil Hardness(Mitsubishi Pencil)	-	-	H	AAMA 2605-13
Dry Adhesion-Loss of Adhesion	%	-	0	AAMA 2605-13
Wet Adhesion-Loss of Adhesion	%	-	0	AAMA 2605-13
Boiling Water Adhesion-Loss of Adhesion	%	-	0	AAMA 2605-13
Abrasion Resistance(Abrasion Coefficient(1°))	L/mil	-	109	AAMA 2605-13
Impact Resistance	-	-	No Defects	AAMA 2605-13
Muratic Acid Resistance(10 % HCl, 15 min)	-	-	No Defects	AAMA 2605-13
Color Difference after Nitric Acid Resistance(70 % HNO ₃ , 30 min)	-	-	0.5	AAMA 2605-13
Mortar Resistance	-	-	No Defects	AAMA 2605-13

- Usage of Report : QUALITY CONTROL

Bok Gyeong
Prepared by Bok Gyeong
Tel : 02-2992-3685

Jung Hantae
Reviewed by Jung Hantae
Tel : 1577-0891(APS 01-48)

2024.01.11

Korea Testing & Research Institute
President



QR Code for forgery

Korea Testing & Research Institute
President



QR Code for forgery

Fabric (High Density Waterproof Canvas)



BEYOND ASIAN HUB, TOWARD GLOBAL WORLD

TEST REPORT

98, Gyojukwon-ro, Gwacheon-si, Gyeonggi-do, 13810, Korea TEL 82-31-499-5390 FAX 82-31-499-6867

Report No : TAK-2023-177363 Receipt Date : 2023.12.21.
 Representative : Hong, Sung-Chul Test Completion Date : 2024.01.11.
 Company name : MARECAMP CO., Ltd.
 Address : 182, Sinnam-ro, Namyang-eup, Hwaseong-si, Gyeonggi-do, Republic of Korea.

Sample name : Goverland Fabric

TEST RESULTS	
TEST ITEM	TEST RESULT
Color Fastness to Light (grade)	KS K ISO 105-B02:2014 (Xenon arc, A1 Exposure cycle, Rel. Method 3)
Blue scale 4	Over 4
Fabric Count (threads/cm)	KS K ISO 7211-2:1984 C Method
Ward	47
Wort	34
*Note) The density of parallel yarns is counted for each single yarn.	
Water Resistance (cmH ₂ O)	KS K ISO 811:2018 Hydrostatic Pressure Test
	508
*Note) 1. Temperature and Humidity : (20 ± 2) °C, (65 ± 4) % R.H. 2. The temperature of Water : (20 ± 2) °C 3. The rate of increase of water pressure : 60 cmH ₂ O/min 4. The face side of the specimen has been in contact with the water	

- Continues -

Shin Dong Joon
Prepared by Shin Dong Joon
Tel : 1577-0891(APS 01-48)

Yun Jun Ho
Reviewed by Yun Jun Ho
Tel : 1577-0891(APS 01-48)

2024.01.11

Korea Testing & Research Institute
President



QR Code for forgery

Korea Testing & Research Institute
President



QR Code for forgery

GOVERLAND Representative product (manufactured directly)

The rooftop tents and swing awnings listed below are products that we manufacture directly. We can modify their sizes through supply contracts, making both production and supply possible.

Rooftop Tent (Z High-Top)



Swing Shelter & Shower Tent



270 degrees



180 degrees



GOVERLAND®

"Connecting daily life with rest in nature."

Truck Camper the GOAT



An Expanding Interior Space



Feel the Spacious Openness Inside.



Standing access to the GOTA camper.

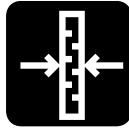

Applied High-Insulation GRP



Accessories can be mounted on the installed rails.



Lightweight yet strong crafted with in-house aluminum.

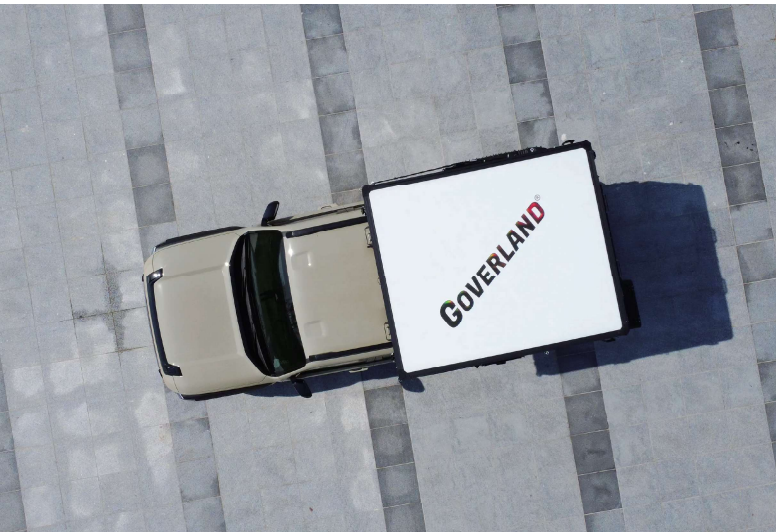





GOVERLAND®



US Office
Calabasas, CA and
1 (805) 428-3766

South California Distribution
American Van Works
1 (714) 622-4047

East Coast Distribution
Lian US Rv & Marine, LLC
1 (714) 622-4047

